



European Tractor Pulling Committee
Tech and Safety Board

Willem Wempe (NL) willemwempe@hetnet.nl
Peter de Wit (NL) etpc@hetnet.nl
Hans Chistian Schmidt (DK) hca.schmidt@gmail.com
Chris van Goethem (B) chris.vangoethem@airplus.be
Klaus Hünting (D) Klaus_Huening@gmx.de
Torbjorn Andersson (S) andersson.bjorkerod@telia.com

Date : 22 June 2026

To : ETPC Members
ETPC Eurocup PS teams
ETPC DDC
ETPC Daily Board
ETPC Tech & Safety Board

Ref: Clarification of the ETPC rulebook relating to Turbo limit ProStocks.

Dear Friends,

Our ETPC Rulebook says in **Chapter 12 Limits 3. Pro Stocks** (page 88):

- Maximum of one (1) turbocharger, maximum diameter inlet wheel 129,5 mm(5.1 inch), maximum diameter exhaust wheel 133,4 mm (5.25 inch).

It was brought to our attention that some teams were making a turbo inlet bypass system that gave them a big increase in horsepower.

They modified the MWE groove system to make a much bigger inlet than the 5.1 inch wich is the limit. The drawings below show how.

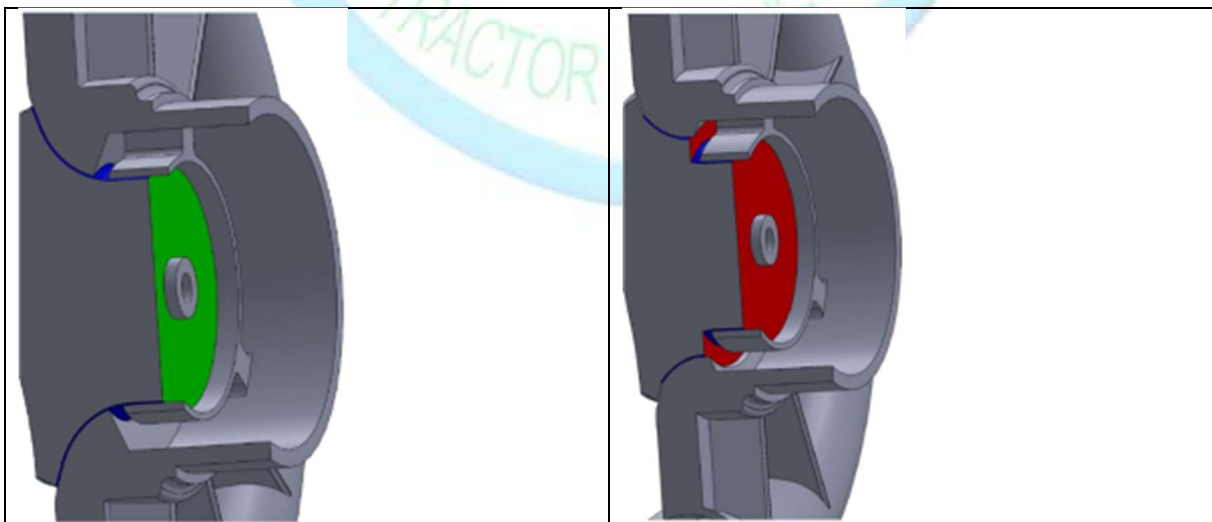



European Tractor Pulling Committee Tech and Safety Board

Willem Wempe (NL) willemwempe@hetnet.nl
Peter de Wit (NL) etpc@hetnet.nl
Hans Christian Schmidt (DK) hca.schmidt@gmail.com
Chris van Goethem (B) chris.vangoethem@airplus.be
Klaus Huenting (D) Klaus_Huenting@gmx.de
Torbjorn Andersson (S) andersson.bjorkerod@telia.com

The red modification is of course not allowed.

To prevent this cheating from now on we made a clarification how the 5.1 inch turbo in the Pro Stock class must be checked and what the dimensions must be. Most of them are maximum dimensions, clearance between blades and housing is most times less.

ProStock Turbo measuring

Prostock turbo limit is 129,54 mm inlet wheel measured at the face of the wheel.
It must stay 129,54 till the radius.

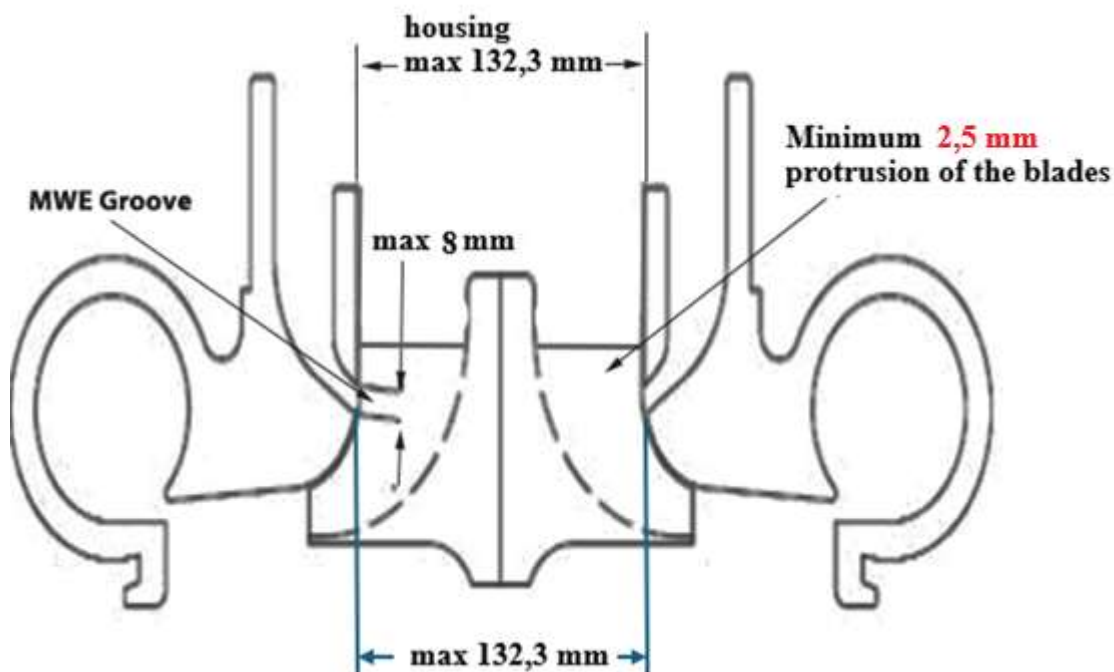

Map width enhancement is allowed. Maximum map width limit of 8 mm. MWE groove must be inside neck area where intake cover is measured maximum 132.3 mm.

Compressor wheel must protrude into the max 132.3 mm opening at least 6 mm.

Intake housing to be no larger than 132.3 mm at the face of the wheel.



European Tractor Pulling Committee

Tech and Safety Board

Willem Wempe (NL) willemwempe@hetnet.nl
Peter de Wit (NL) etpc@hetnet.nl
Hans Chistian Schmidt (DK) hca.schmidt@gmail.com
Chris van Goethem (B) chris.vangoethem@airplus.be
Klaus Hünting (D) Klaus_Huening@gmx.de
Torbjorn Andersson (S) andersson.bjorkerod@telia.com

Measurements:

ETPC Rulebook

Maximum diameter inlet wheel 129,5 mm (5.1 inch) **measured at the face of the wheel,**

Maximum diameter exhaust wheel 133,4 mm (5.25 inch) **measured at the face of the wheel.**

Max diameter inlet housin neck is set to 132,3 because old turbo housings are often eroded or polished after a few years.

All air must enter through the maximum 132.3 mm inlet opening and leave through maximum 135,7 mm exhaust opening.

Best Regards

ETPC Tech & safety Board

